

HYDRO, AERO, UNDERWATER SHOWER MASSAGE
AND UNDERWATER VACUUM MASSAGE BATH



UNDERWATER
SHOWER
MASSAGE

USM

+

UVM

UNDERWATER
VACUUM
MASSAGE



Hose for USM and UVM nozzles



Nozzles for underwater shower massage (USM)



Nozzle for underwater vacuum massage (UVM)

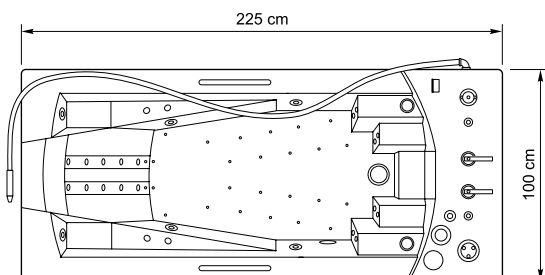
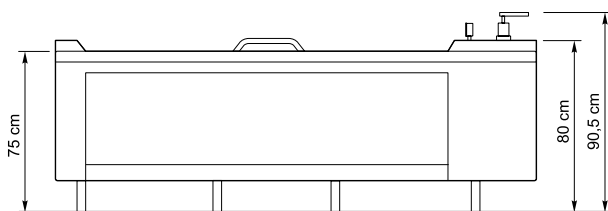

MEASURES FOR COMMUNICATIONS

- Sanitation opening Ø 100 mm (both locations are suitable)
- H Hot water (3/4" stopcock max. 16 cm high from the floor)
- C Cold water (3/4" stopcock max. 16 cm high from the floor)
- ◇ Supply wire cable (2 m long)
- ◇ Additional earthing wire cable (2 m long)
- M Mineral water (3/4" stopcock max. 16 cm high from the floor)

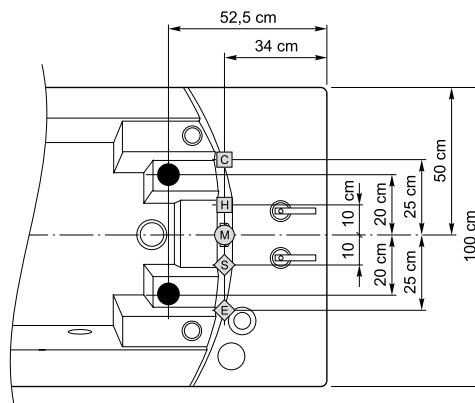

**USM-UVM
USM**

- Underwater shower massage (USM)
- Underwater vacuum massage (UVM)
(only in the case of USM-UVM)
- Bath

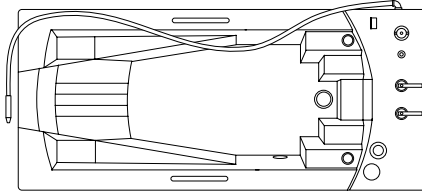

	USM-UVM		USM	
Power (kW)	1,5	1,5	1,5	1,5
Current (A)	7,0	4,0	7,0	4,0
Voltage (V)	~230	3×400	~230	3×400
Frequency (Hz)	50	50	50	50
Nano jets	-	-	-	-
Micro jets	-	-	-	-
Midi jets	-	-	-	-
Air jets	-	-	-	-
USM nozzles	6	6	6	6
UVM nozzle	1	1	-	-

SPA-LUX

- Soft wave hydromassage
with four continuously
changing zones
- Bath

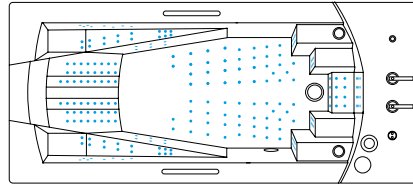

Power (kW)	1,5
Current (A)	7,0
Voltage (V)	~230
Frequency (Hz)	50
Nano jets	240
Micro jets	-
Midi jets	-
Air jets	-
USM nozzles	-
UVM nozzle	-

HYDRO

- Hydromassage from sides
- Hydromassage from back
- Hydromassage for hands
- Hydromassage for foot
- Bath

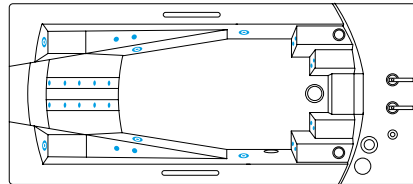

Power (kW)	2,2
Current (A)	4,8
Voltage (V)	~3 × 400
Frequency (Hz)	50
Nano jets	-
Micro jets	22
Midi jets	6
Air jets	-
USM nozzles	-
UVM nozzle	-

AERO

- Air massage from bottom
- Bath

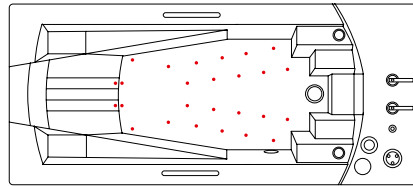

Power (kW)	0,74
Current (A)	1,9
Voltage (V)	~3 × 400
Frequency (Hz)	50
Nano jets	-
Micro jets	-
Midi jets	-
Air jets	26
USM nozzles	-
UVM nozzle	-

BATH

- Bathtub body
- Frame with adjustable feet
- 2 front and 2 side panels
- Drain
- Hot and cold water stopcock
- Mixer with handshower
- Stainless steel handles

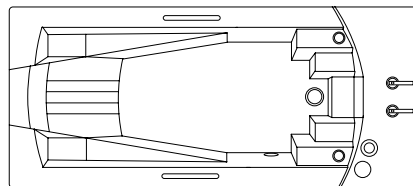

Power (kW)	-
Current (A)	-
Voltage (V)	-
Frequency (Hz)	-
Nano jets	-
Micro jets	-
Midi jets	-
Air jets	-
USM nozzles	-
UVM nozzle	-

AQUATOR THERAPY BATHS CAN BE ASSEMBLED WITH A SINGLE MASSAGE SYSTEM OR MULTIPLE SYSTEMS. PLEASE CONTACT OUR SALES FOR FURTHER INFORMATION.

TECHNICAL DATA

1. WATER PRESSURE IN THE SYSTEM OF UNDERWATER SHOWER MASSAGE DEVICE

Nozzle 7 mm	0-0,36 MPa
Nozzle 9 mm	0-0,33 MPa
Nozzle 11 mm	0-0,3 MPa

2. TIME FOR FILLING THE BATH

In the case of water pressure in the supplying system about 0,35 MPa and hot and cold water connections 3/4" – approximately 4 minutes.

3. TIME FOR DRAINING THE BATH

In the case of sanitation opening in the floor with Ø 100 mm and sanitation magistral pipe under the floor with Ø 100 mm – approximately 4 minutes.

4. MEASURES FOR CONNECTIONS OF HOT AND COLD WATER – 3/4".

5. MEASURES FOR CONNECTIONS OF MINERAL-, SEA- AND IODINE-BROMINE WATER – 3/4".

6. MEASURE FOR WATER DRAIN CONNECTION – Ø 100 mm.